

LARIUS®

Transfer - Extrusion - Injection pumps - Paint spraying equipment

www.larius.eu

OPERATING AND MAINTENANCE INSTRUCTION

Mist-less manual spraying gun L400



manufacturing in Italy
since 1969

LARIUS[®]

PAINT SPRAYING EQUIPMENT



Larius S.r.l., founded in 1969, designs and manufactures painting equipment, and transfer and extrusion pumps.



Larius S.r.l. is a company with a great industrial tradition and an innovative technological culture. Internal production, based on innovation and research, is flexible to industry changes in order to achieve the primary objective of creating value.



Larius S.r.l. is the only leading Italian company in the international market. The brand is distributed worldwide, through an extensive network of distributors and resellers, and is a guarantee of Total Product Quality in the industrial, plastics, construction, wood and road marking sectors.



*Once again
a step ahead...*

**Each day we strive further
to satisfy your work
requirements**

**INVEST IN LARIUS
INVEST IN
PRODUCTIVITY**

www.larius.eu

MIST-LESS SPRAYING GUNS

MANUAL - AUTOMATIC

ADVANTAGE OF USE

The manual gun **Mist-less L400** allows an easy control and adjustment of the spraying range. To switch between Mist-less and Mist-Clean 2 base you just need to replace the spraying coupling. All guns, light and handy, are easy to clean and service. All parts getting in contact with the product are made of stainless steel.

The automatic gun **Mist-less L200** ensures the best performance during the painting of metal and wood. All parts in contact with the product are made of stainless steel in order to grant high resistance and long life over time. Components are easy to assemble and disassemble during maintenance operations.

All guns offer the possibility to:

- open or close the product recirculation;
- choose between two products inlets (Mist-less / Mist-clean). The two systems are fully interchangeable with no need to modify the body of the gun;
- provide quick couplings to speed up the connection of the gun to the air hose;
- provide the high precision cap to adjust the opening of the product flow.

GUNS



Mist-less manual gun L400
for Mist-less tip
Code 21800



Mist-less manual gun L400
complete with Mist-Clean 2 base for Super Fast Clean
or Top spraying Clean tip
Code 21801



Mist-less automatic gun L200
with side inlets for Mist-less tip
Code 21340



Mist-less automatic gun L200
with side inlets complete with
Mist-Clean 2 base for Super Fast Clean
or Top spraying Clean tip
Code 21342



Mist-less automatic gun L201
with rear inlets for Mist-less tip
Code 21341



Mist-less automatic gun L201
with rear inlets complete with
Mist-Clean 2 base for Super Fast Clean
or Top spraying Clean tip
Code 21343

RANGE

Automatic gun MA98L
low pressure
Code 11300



Airless spraying gun AT250
complete with Super fast Clean base
Code 11200



Airless spraying gun AT300
complete with Super fast Clean base
Code 11000



Airless spraying gun L91X
complete with Super fast Clean base
Code 11130



Airless spraying LA95
Automatic - high pressure
Code 11700



Gun RAC2
Automatic - low pressure
Code 14100



Airless gun PLA
cm 130 complete with Super
Fast Clean base
Code K11421

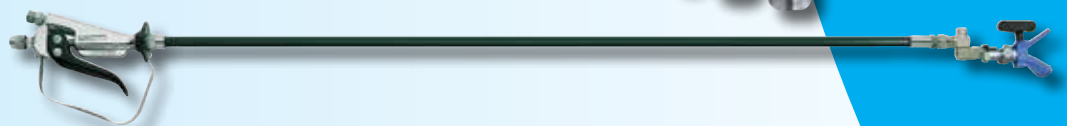



LARIUS[®]

MIST-LESS GUN L400

FOREWORD	p.1	P ROUTINE MAINTENANCE	p.18
WARNINGS	p.8	REPLACE PRODUCT FILTER	p.18
A WORKING PRINCIPLE	p.9	REPLACE PRODUCT GASKET	p.19
B TECHNICAL DATA	p.9	REPLACE COUPLING GROUP	p.21
C TRANSPORT AND UNPACKING	p.10	REPLACE AIR VALVE GASKET	p.22
D SAFETY RULES	p.10	REPLACE BUSHING GASKET	p.24
E DESCRIPTION OF THE EQUIPMENT	p.11	REPLACE PRODUCT HOUSE GASKET	p.25
Safety regulation	p.12	Q MIST-LESS MANUAL GUN L400	p.27
F FLUID INJECTION HAZARD	p.13	R SUPER FAST-CLEAN NOZZLE	p.29
G PRESSURE DISCHARGING PROCEDURE	p.13	S MIST-LESS NOZZLES	p.30
H EQUIPMENT MISUSE HAZARD	p.14	T NOZZLES TOP SPRAYING CLEAN	p.30
I HOSE SAFETY	p.14	U BASE MIST-CLEAN 2	p.30
L FIRE OR EXPLOSION HAZARD	p.14	V KIT AND SPARE PARTS	p.30
M MOVING PARTS HAZARD	p.15	W LONG FILTER MATERIAL HOSE KIT REF.21980..	p.31
N SETTING-UP	p.15	X TROUBLESHOOTING	p.32
O OPERATION	p.16	Y VERSIONS	p.33

**WE ADVISE THE USE OF THIS EQUIPMENT ONLY BY PROFESSIONAL OPERATORS.
ONLY USE THIS MACHINE FOR USAGE SPECIFICALLY MENTIONED IN THIS MANUAL.**

Thank you for choosing a **LARIUS S.R.L.** product.
As well as the product purchased,
you will receive a range of support services
enabling you to achieve the results desired,
quickly and professionally.

Due to a constant product improvement programme, the factory reserves the right to modify technical details mentioned in this manual without prior notice.

This manual is to be considered as an English language translation of the original manual in Italian. The manufacturer shall bear no responsibility for any damages or inconveniences that may arise due to the incorrect translation of the instructions contained within the original manual in Italian.



WARNINGS

The table below provides the meaning of the symbols used in this manual in relation to using, earthing, operating, maintaining, and repairing of this equipment.

	<p>Read this operator's manual carefully before using the equipment. An improper use of this machine can cause injuries to people or things. Do not use this machine when under the influence of drugs or alcohol. Do not modify the equipment under any circumstances. Use products and solvents that are compatible with the various parts of the equipment, and read the manufacturer's warnings carefully. See the Technical Details for the equipment given in the Manual. Check the equipment for worn parts once a day. If any worn parts are found, replace them using ONLY original spare parts. Keep children and animals away from work area. Comply with all safety standards.</p>
	<p>It indicates an accident risk or serious damage to equipment if this warning is not followed.</p>
	<p>Report any risk of chemical reaction or explosion if this warning has not been given. There is a risk of injury or serious lesion related to contact with the jet from the spray gun. If this should occur, IMMEDIATELY contact a doctor, indicating the type of product injected.</p>
	<p>Do not spray before the guard has been placed over the nozzle and the trigger on the spray gun. Do not put your fingers in the spray gun nozzle. Once work has been completed, before carrying out any maintenance, complete the decompression procedure explained in this manual.</p>
	<p>It indicates important recommendations about disposal and recycling process of products in accordance with the environmental regulations.</p>
	<p>It reports any danger of electric shock if the warning and presence of live electrical parts has not been indicated. Store in a dry place and do not expose to the rain. Check that the cables are in good condition. Switch off the equipment and discharge any electricity before cleaning or maintaining the equipment.</p>
	<p>It indicates the presence of any clamps with earth cables. Use ONLY 3-wire extension cords and grounded electrical outlets. Before starting work make sure that the electrical system is earthed and that it complies with safety standards.</p>
	<p>FIRE AND EXPLOSION HAZARD Solvent and paint fumes in work area can ignite or explode. To help prevent fire and explosion:</p> <ul style="list-style-type: none"> - Use equipment ONLY in well ventilated area. - Eliminate all ignition sources, such as pilot lights, cigarettes and plastic drop cloths (potential static arc). - Ground equipment and conductive objects. - Use only grounded hoses. - Do not use trichloroethane, methylene chloride, other halogenated hydrocarbon solvents or fluids containing such solvents in pressurized aluminium equipment. Such use can cause serious chemical reaction and equipment rupture, and result in death, serious injury, and property damage. <p>If electrical shocks or discharges are encountered the operation being carried out using the equipment must be stopped immediately. Keep a fire extinguisher at hand in the immediate vicinity of the work area.</p>



	<p>INJECTION HAZARD High-pressure fluid from gun, hose leaks, or ruptured components will pierce skin. To help prevent injection, always:</p> <ul style="list-style-type: none"> - Engage trigger lock when not spraying. - Do not put your hand over the spray tip. Do not stop or deflect leaks with your hand, body or other. - Do not point gun at anyone or at any part of the body. - Never spray without tip guard. - Do pressure relief if you stop spraying or being servicing sprayer and before any maintenance operations. - Do not use components rated less than sprayer Maximum Working Pressure. - Never allow children to use this unit - Brace yourself; gun may recoil when triggered. <p>If high pressure fluid pierces your skin, the injury might look like “just a cut”, but it is a serious wound! Get immediate medical attention.</p>
	<p>It is obligatory to wear suitable clothing as gloves, goggles and face shield. Wear clothing that complies with the safety standards in force in the country in which the equipment is used. Do not wear bracelets, earrings, rings, chains, or anything else that may hinder the operator's work. Do not wear clothing with wide sleeves, scarves, ties, or any other piece of clothing that could get tangled up in moving parts of the equipment during the work, inspection, or maintenance cycles.</p>

A WORKING PRINCIPLE

MIST-LESS painting combines the qualities of airless technology with those of low-pressure application providing superior quality finishing with less material waste.

The **MIST-LESS** sprayguns allows:

- 15-35% product saving
- Overspray reduced to the minimum
- High quality finishing

The **MIST-LESS** sprayguns are equipped with a self-cleaning nozzle with the following advantages:

- Reduced maintenance
- Long working life
- The nozzle does not have to be removed for cleaning, but simply turned 180°, based on the same principle as Fast-Clean.

B TECHNICAL DATA

MIST-LESS GUN	MANUAL VERSION
Max operating pressure	250 bar (3625 psi)
Air inlet	ø=8mm
Inlet port size	STANDARD G _j 1/4" (M)
	1/4" NPS (M)*
Weight	590 g

*Available on request

PARTS OF THE SPRAY-GUN IN CONTACT WITH THE MATERIAL
Stainless steel AISI 420B, PTFE, Aluminium, Stainless Steel AISI 303, Tungsten carbide

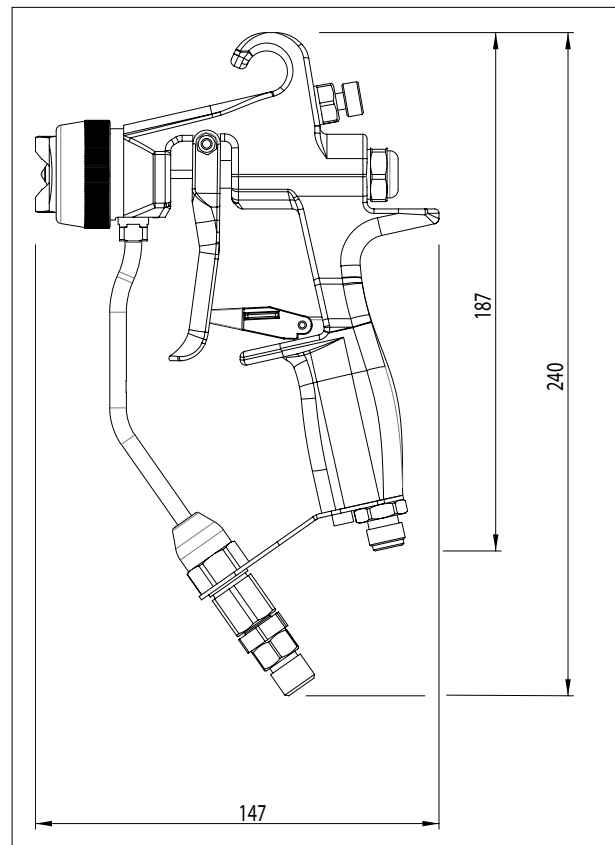



C TRANSPORT AND UNPACKING

- The manufacturer will not be responsible for the unloading operations and transport to the workplace of the machine.
- Check the packing is undamaged on receipt of the equipment.
Unpack the machine and verify if there has been any damage due to transportation.
In case of damage, call immediately **LARIUS** and the Shipping Agent. All the notices about possible damage or anomalies must arrive timely within 8 days at least from the date of receipt of the plant through Registered Letter to the Shipping Agent and to **LARIUS**.



The disposal of packaging materials is a customer's competence and must be performed in accordance with the regulations in force in the country where the plant is installed and used. It is nevertheless sound practice to recycle packaging materials in an environment-friendly manner as much as possible.

D SAFETY RULES

- THE EMPLOYER SHALL TRAIN ITS EMPLOYEES ABOUT ALL THOSE RISKS STEMMING FROM ACCIDENTS, ABOUT THE USE OF SAFETY DEVICES FOR THEIR OWN SAFETY AND ABOUT THE GENERAL RULES FOR ACCIDENT PREVENTION IN COMPLIANCE WITH INTERNATIONAL REGULATIONS AND WITH THE LAWS OF THE COUNTRY WHERE THE PLANT IS USED.
- THE BEHAVIOUR OF THE EMPLOYEES SHALL STRICTLY COMPLY WITH THE ACCIDENT PREVENTION AND ALSO ENVIRONMENTAL REGULATIONS IN FORCE IN THE COUNTRY WHERE THE PLANT IS INSTALLED AND USED.



Read carefully and entirely the following instructions before using the product. Please save these instructions in a safe place.

The unauthorised tampering/replacement of one or more parts composing the machine, the use of accessories, tools, expendable materials other than those recommended by the manufacturer can be a danger of accident.



The manufacturer will be relieved from tort and criminal liability.

- KEEP YOUR WORK PLACE CLEAN AND TIDY. DISORDER WHERE YOU ARE WORKING CREATES A POTENTIAL RISK OF ACCIDENTS.
- ALWAYS KEEP PROPER BALANCE AVOIDING UNUSUAL STANCE.
- BEFORE USING THE TOOL, ENSURE THERE ARE NOT DAMAGED PARTS AND THE MACHINE CAN WORK PROPERLY.
- ALWAYS FOLLOW THE INSTRUCTIONS ABOUT SAFETY AND THE REGULATIONS IN FORCE.
- KEEP THOSE WHO ARE NOT RESPONSIBLE FOR THE EQUIPMENT OUT OF THE WORK AREA.
- **NEVER** EXCEED THE MAXIMUM WORKING PRESSURE INDICATED .
- **NEVER** POINT THE SPRAY GUN AT YOURSELVES OR AT OTHER PEOPLE . THE CONTACT WITH THE CASTING CAN CAUSE SERIOUS INJURIES.
- IN CASE OF INJURIES CAUSED BY THE GUN CASTING, SEEK IMMEDIATE MEDICAL ADVICE SPECIFYING THE TYPE OF THE PRODUCT INJECTED. **NEVER** UNDERVALUE A WOUND CAUSED BY THE INJECTION OF A FLUID.
- ALWAYS DISCONNECT THE SUPPLY AND RELEASE THE PRESSURE IN THE CIRCUIT BEFORE PERFORMING ANY CHECK OR PART REPLACEMENT OF THE EQUIPMENT .
- NEVER MODIFY ANY PART IN THE EQUIPMENT. CHECK REGULARLY THE COMPONENTS OF THE SYSTEM. REPLACE THE PARTS DAMAGED OR WORN.
- TIGHTEN AND CHECK ALL THE FITTINGS FOR CONNECTION BETWEEN PUMP , FLEXIBLE HOSE AND SPRAY GUN BEFORE USING THE EQUIPMENT.
- ALWAYS USE THE FLEXIBLE HOSE SUPPLIED WITH STANDARD KIT. THE USE OF ANY ACCESSORIES OR TOOLING OTHER THAN THOSE RECOMMENDED IN THIS MANUAL, MAY CAUSE DAMAGE OR INJURE THE OPERATOR.
- THE FLUID CONTAINED IN THE FLEXIBLE HOSE CAN BE VERY DANGEROUS . HANDLE THE FLEXIBLE HOSE CAREFULLY . DO NOT PULL THE FLEXIBLE HOSE TO MOVE THE EQUIPMENT . NEVER USE A DAMAGED OR A REPAIRED FLEXIBLE HOSE.



E DESCRIPTION OF THE EQUIPMENT

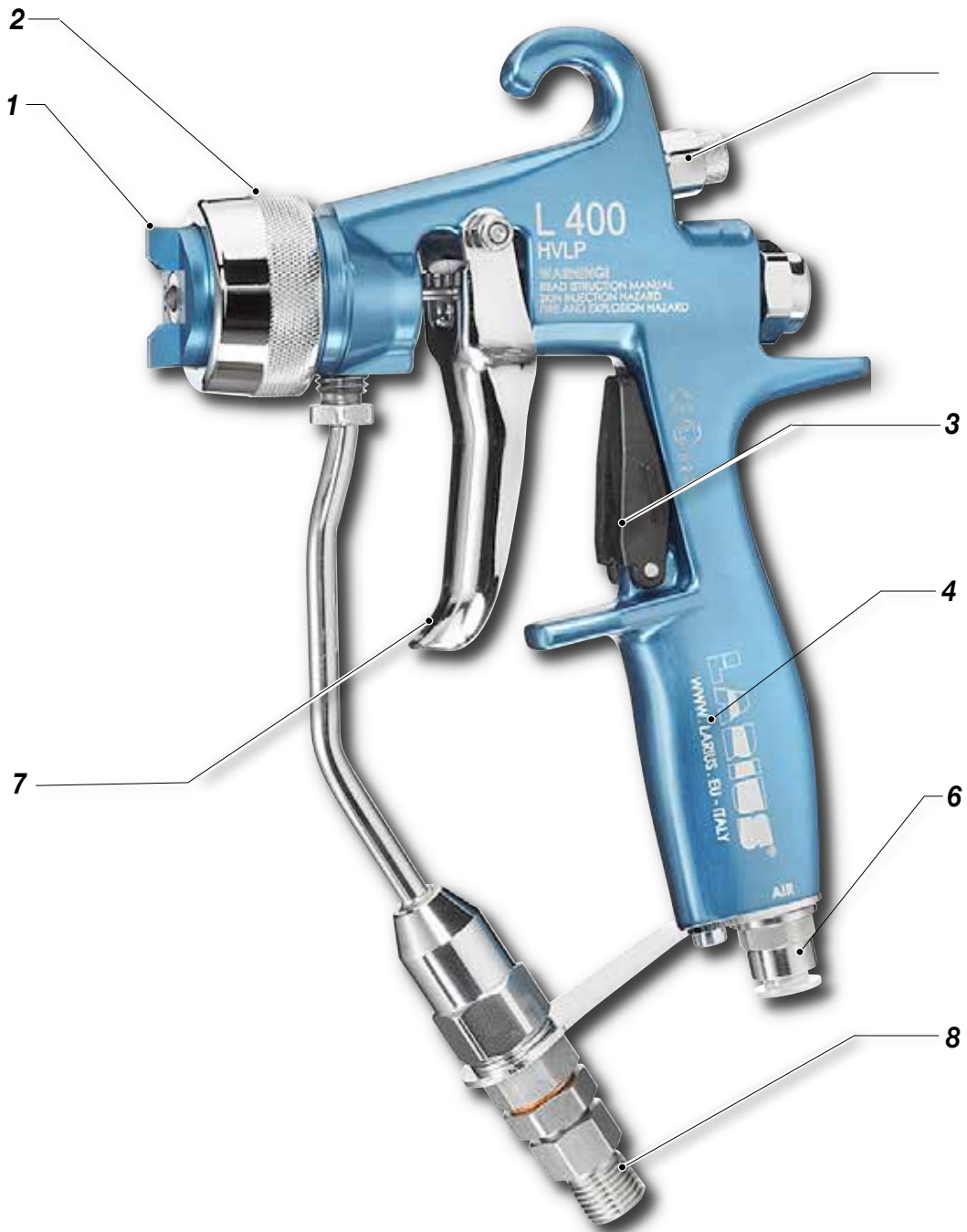



POS.	Description
1	Head
2	Locking ring nut
3	Safety lever
4	Gun body

	Description
5	Gun air adjusting screw
6	Air inlet fitting
7	Trigger
8	Material inlet fitting



 The high speed of the product in the hose can create static electricity through discharges and sparks. It is suggested to earth the equipment.

 The pump is earthed through the earth cable of the supply.

 The gun is earthed through the high pressure flexible hose.

All the conductors near the work area must be earthed.

- NEVER SPRAY OVER FLAMMABLE PRODUCTS OR SOLVENTS IN CLOSED PLACES.
- NEVER USE THE TOOLING IN PRESENCE OF POTENTIALLY EXPLOSIVE GAS.

 Always check the product is compatible with the materials composing the equipment (*pump, spray gun, flexible hose and accessories*) with which it can come into contact. Never use paints or solvents containing halogen hydrocarbons (*as the methylene chloride*).

 If these products come into contact with aluminium parts can provoke dangerous chemical reactions with risk of corrosion and explosion.



 IF THE PRODUCT TO BE USED IS TOXIC, AVOID INHALATION AND CONTACT BY USING PROTECTION GLOVES, GOGGLES AND PROPER FACE SHIELDS.





 TAKE PROPER SAFETY MEASURES FOR THE PROTECTION OF HEARING IN CASE OF WORK NEAR THE PLANT.

- WHENEVER YOU STOP DISPENSING, EVEN FOR A MOMENT, ALWAYS SET THE GUN TRIGGER LOCK. FULLY RELEASE THE TRIGGER AND ROTATE THE TRIGGER LOCK FORWARD (see page 12).
- USE EXTREME CAUTION WHEN CLEANING OR CHANGING THE FLUID NOZZLE. IF THE NOZZLE CLOGS WHILE DISPENSING, FULLY RELEASE THE TRIGGER IMMEDIATELY. ALWAYS FOLLOW THE PRESSURE RELIEF PROCEDURE, BELOW, BEFORE WIPING OFF BUILD-UP AROUND THE NOZZLE OR REMOVING THE NOZZLE TO CLEAN IT.
- DO NOT POINT THE GUN UPWARDS DURING CLEANING OPERATIONS.



- DO NOT RUB THE SPRAYGUN WITH CLOTHS SOAKED IN SOLVENT.



- DO NOT IMMERSE THE SPRAYGUN IN SOLVENT.



- DO NOT USE METAL TOOLS TO CLEAN THE NOZZLES, SINCE THEY MAY BE SCRATCHED AND CAUSE UNEVEN SPRAYING.

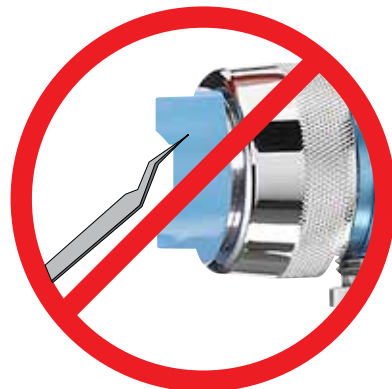



F FLUID INJECTION HAZARD



This is a high pressure dispensing gun. Fluid dispensed under high pressure could be injected through your skin and into your body. This could cause extremely serious injury, including the need for amputation. Also, fluid injected or splashed into the eyes or on the skin can cause serious damage.

	Never put hand or fingers over the nozzle.
	Never wipe off build-up around the fluid nozzle until pressure is fully relieved and the gun trigger lock is engaged.
	Never try to stop or deflect leaks with your hand or body.

Always follow the Pressure Discharging Procedure, as hereby described, before cleaning or removing the fluid nozzle or servicing any system equipment.

MEDICAL ALERT – FLUID INJECTION WOUNDS

If any fluid appears to penetrate your skin, get EMERGENCY MEDICAL CARE AT ONCE. DO NOT TREAT AS A SIMPLE CUT. Tell the doctor exactly what fluid was injected.

	Injection into the skin is a traumatic injury. It is important to treat the injury surgically as soon as possible. Do not delay treatment to research toxicity.
	Toxicity is a concern with some exotic materials injected directly into the blood stream. Consultation with a plastic surgeon may be advisable.

G PRESSURE DISCHARGING PROCEDURE

To reduce the risk of serious injury, including fluid injection, splashing in the eyes or on skin, always follow this procedure whenever the dispensing equipment is shut off, when checking or servicing any part of system, when installing, cleaning or changing nozzles and whenever you stop dispensing.

- Fully release the gun trigger and set the gun trigger lock by rotating the trigger lock forward.

- Shut off the supply pump.
- Hold a metal part of the gun firmly to the side of a grounded metal waste container.



- Disengage the trigger lock (**G1**) by rotating the trigger lock backward. Trigger the gun to relieve fluid pressure.

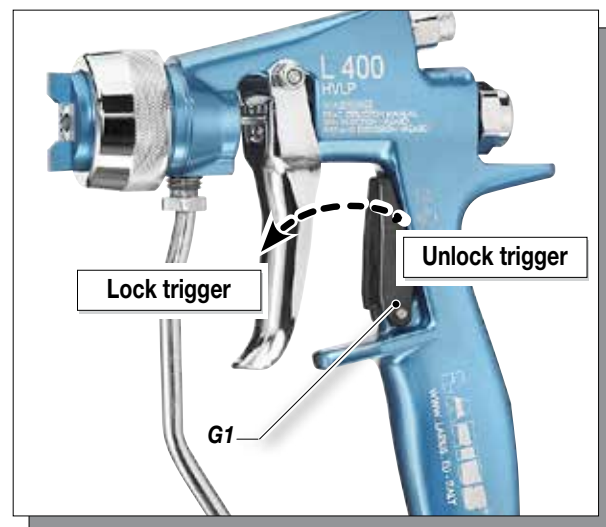

- Fully release the gun trigger and set the gun trigger lock (**G1**) by rotating the trigger lock forward.
- Open the pump drain valve to help relieve fluid pressure in the pump, hose, and gun. Triggering the gun to relieve pressure may not be sufficient. Have a container ready to catch the drainage.
- Leave the drain valve open until you are ready to dispense again.



 If you suspect that the nozzle or hose is clogged or that pressure has not been fully relieved, after following the steps above, very slowly loosen the hose end coupling and relieve pressure gradually; then loosen completely. Now clear the nozzle or hose obstruction.

- Tighten all fluid connections securely before each use. High pressure fluid can dislodge a loose coupling or allow high pressure fluid to be emitted from the coupling
- Never use a damaged hose. If any of these conditions exist, replace the hose immediately.

 **Before each use, check the entire hose for cuts, leaks, abrasion, bulging cover, or damage or movement of the hose couplings.**

H EQUIPMENT MISUSE HAZARD

Any misuse of the dispensing equipment or accessories, such as overpressurizing, modifying parts, using incompatible chemicals and fluids, or using worn or damaged parts, can cause them to rupture and result in serious injury, including fluid injection and splashing fluid in the eyes or on the skin, or in fire, explosion or property damage.

 **The maximum working pressure of the gun is 110 bar. Do not exceed the maximum Working pressure.**

Be sure that all dispensing equipment and accessories are properly rated to withstand the pressures developed by your system. Never exceed the maximum working pressure of your gun model.

 **Be sure all fluids and solvents used are chemically compatible with the "WETTED PARTS" shown in the TECHNICAL DATA. Always read the fluid and solvent manufacturer's literature before using any fluid or solvents in your system.**

- Do not try to recouple high pressure hose or mend it with tape or any other device. A repaired hose cannot contain the high pressure fluid.
- Handle and route hoses carefully.

 **Do not pull on hoses to move equipment. Do not use fluids or solvents which are not compatible with the inner tube and cover of the hose. Do not expose hose to extreme temperatures; check with your hose supplier to determine temperature tolerance.**

Proper hose grounding continuity is essential to maintaining a grounded dispensing system. Check the electrical resistance of your fluid hoses at least once a week. If your hose does not have a tag on it which specifies the maximum electrical resistance, contact the hose supplier or manufacturer for the maximum resistance limits. Use a resistance meter in the appropriate range for your hose to check the resistance. If the resistance exceeds the recommended limits, replace it immediately. An ungrounded or poorly grounded fluid hose can make your system hazardous.



I HOSE SAFETY

High pressure fluid in the hoses can be very dangerous. If the hose develops a leak, split or rupture due to any kind of wear, damage or misuse, the high pressure fluid emitted from it can cause a fluid injection injury or other serious injury or property damage.

L FIRE OR EXPLOSION HAZARD

Static electricity is created by the flow of fluid through the pump and hose. If every part of the equipment is not properly grounded, sparking may occur, and the system may become hazardous. Sparks may also occur when plugging in or unplugging a power supply cord. Sparks can ignite fumes from solvents and the fluid being dispensed, dust particles and other flammable substances, whether you are pumping indoors or outdoors, and cause a fire or explosion, serious injury, and property damage.





	<p>Do not plug in or unplug any power supply cords in the dispensing area when there is any chance of igniting fumes still in the air.</p>
	<p>If you experience any static sparking or feel even a slight shock while using this equipment, STOP DISPENSING IMMEDIATELY. Check for proper grounding of the entire system. Do not use the system again until the cause of the problem is identified and corrected.</p>
	<p></p>

GROUNDING

To reduce the risk of static sparking, ground the pump and all other equipment used or located in the dispensing area. Check your local electrical code for detailed grounding instructions for your area and type of equipment and be sure to ground all of the following equipment.

- Pump: ground the pump by connecting a grounding wire from the pump's grounding lug to a true earth ground.
- Air compressor or hydraulic power supply: ground according to local code and manufacturer's recommendations.
- Fluid hoses: use only grounded hoses with a maximum of 150 mt. Combined hose length to ensure grounding continuity. Refer to hose grounding continuity, above.
- Flo-gun: obtain grounding through connection a properly grounded fluid hose and pump.
- Fluid supply container: according to local code.
- All solvent pails used when flushing: according to local code. Use only metal pails. Do not place the pail on a non-conductive surface, such as paper or cardboard, which interrupts the grounding continuity.
- To maintain grounding continuity when flushing or relieving pressure always hold a metal part of the gun firmly to the side of a grounded metal pail, then trigger the gun.

	<p>Before flushing, be sure the entire system and flushing pails are properly grounded. Refer to GROUNDING, above. Always use the lowest possible fluid pressure, and maintain firm metal-to-metal</p>
	<p>contact between the gun and grounded metal pail during flushing to reduce the risk of fluid injection injury, static sparking and splashing.</p>

M MOVING PARTS HAZARD

Moving parts can pinch or amputate your fingers or other body parts. Keep clear of moving parts when starting or operating your system.

Before checking or servicing the gun, pump, or any other system component follow the **PRESSURE DISCHARGING PROCEDURE** to prevent the pump from starting accidentally.

N SETTING-UP

CONNECT AIR HOSE

- Connect the flexible hose (N1) to the fitting of air gauge (N2) of the pump.

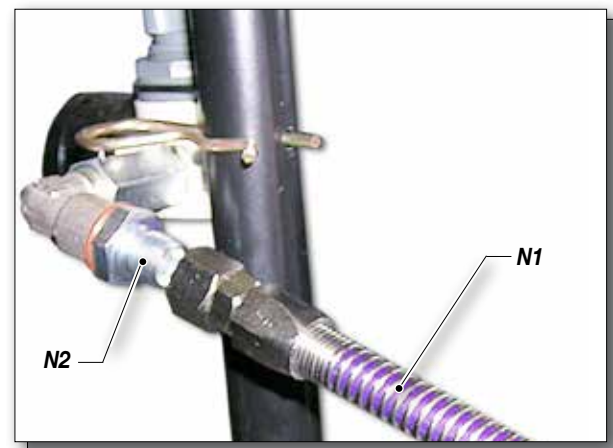

- Connect the flexible hose (N1) to the fitting (N3) of the gun.

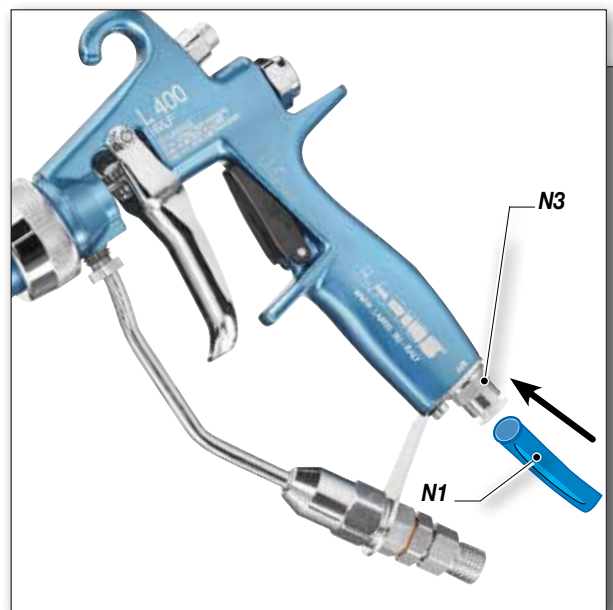



CONNECT PRODUCT HOSE

- Connect the flexible hose for product delivery (N4) to the fitting (N5) of the pump. Tighten the nut (N6) with a suitable wrench (N7).

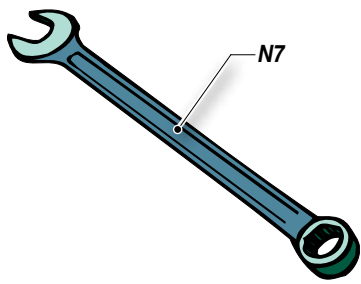
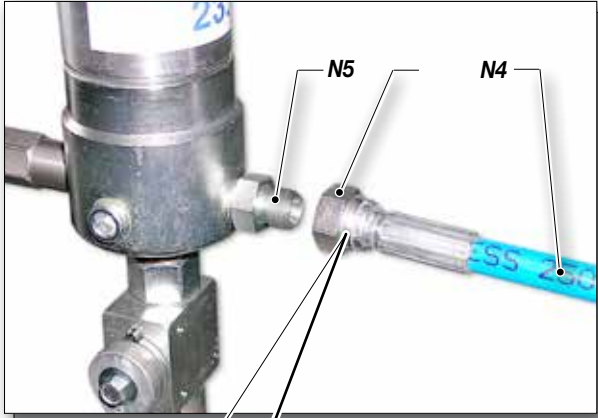

- Connect the flexible hose of product delivery (N4) to the gun (N8). Tighten the nut (N9) with a suitable wrench (N7).

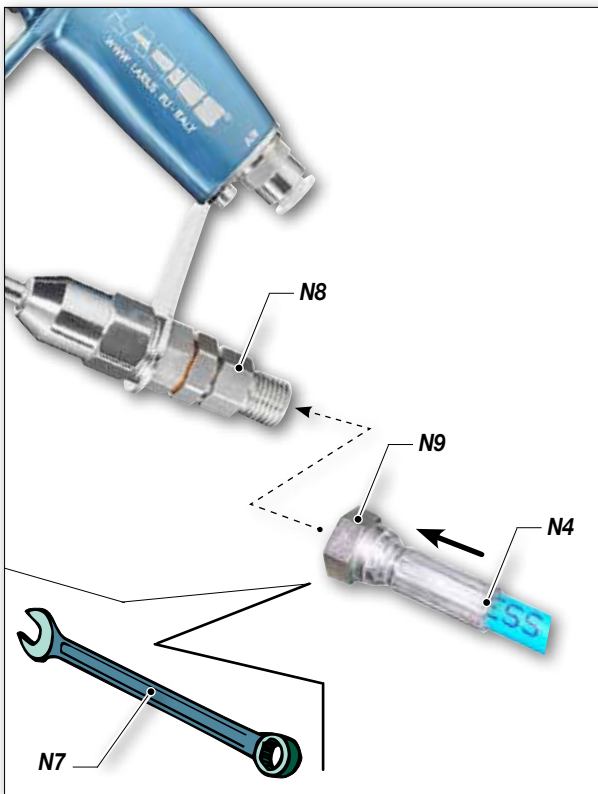

NEVER use sealants on fittings' threads. It is recommended to use the hose provided with the standard kit. **NEVER** use a damaged or a repaired flexible hose.

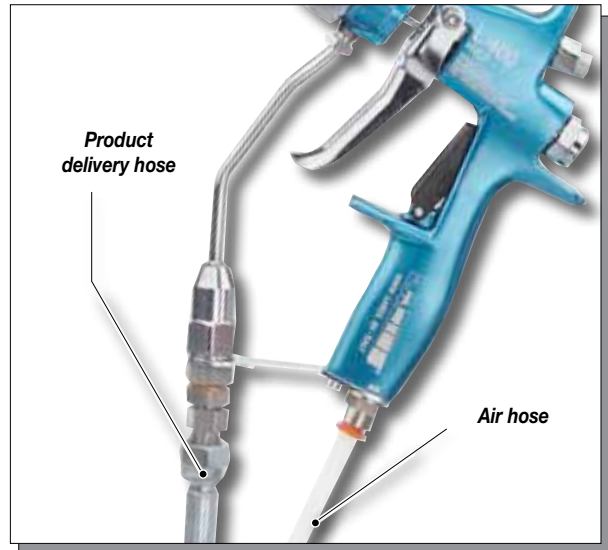

OPERATION

Fluid flow rate is controlled at the pump. Adjust the pump pressure to obtain the desired flow rate; use lowest pressure necessary. The pressure adjustment will depend on hose length, the viscosity of the fluid, and the nozzle size. To dispense fluid with the gun, start the supply pump, disengage the trigger lock, and squeeze the trigger in all the way. Fluid flow begins with the slightest pressure and stops when trigger is released.



To reduce the risk of serious injury, including fluid injection or splashing in the eyes or on skin, always follow the **PRESSURE DISCHARGING PROCEDURE** whenever the dispensing equipment is shut off, when checking or servicing any part of system, when installing or changing nozzles and whenever you stop dispensing. Always engage the trigger lock when the gun is not in use to prevent accidental triggering of the gun.

START OF THE PAINTING OPERATIONS

- Use the equipment only after performing all the **SETTING UP** operations described above.



Before starting the pump it is important that a small amount of atomizing air is sent to the spraygun.

- At this point, the product will flow until reaching the gun and you can start working.



ADJUSTING SPRAYING NOZZLE

- The spraying nozzle can be adjusted according to need by setting the pump operating pressure and the atomization pressure until reaching the required operating conditions.
- For proper spraying of the product, the air and paint coming out of the gun must leave a spraying trace without tails.
- At this point, the product will flow until reaching the gun and you can start working.



NEVER point the spray gun at yourselves or at other people. The contact with the casting can cause serious injuries. In case of injuries caused by the gun casting, seek immediate medical advice specifying the type of the product injected.



Trace of spraying a fluid at low-pressure without using air.



Symmetrical trace of spraying a fluid using air. No tail-end is formed.



TRIGGER LOCK ENGAGED

To engage the trigger lock, release the trigger and rotate the trigger lock (O1) forward.

TRIGGER LOCK DISENGAGED

To disengage the trigger lock (O1), rotate the trigger lock backward.

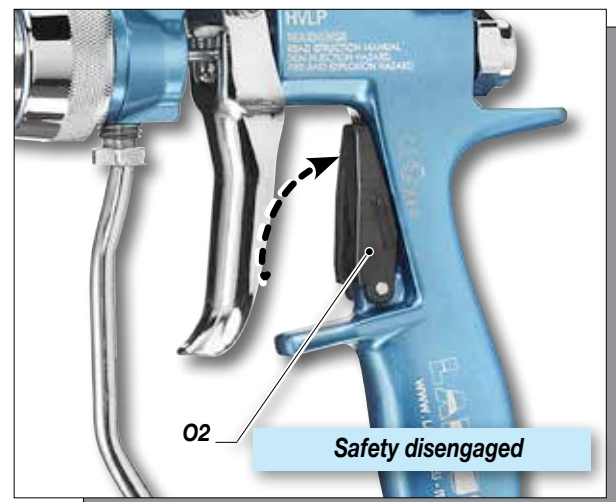
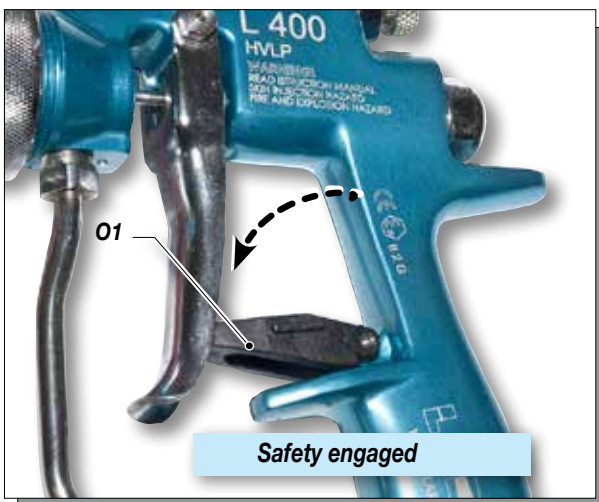



P ROUTINE MAINTENANCE

 To reduce the risk of serious injury, including fluid injection or splashing the eyes or on the skin:

- Always follow the **PRESSURE DISCHARGING PROCEDURE** (see page 12) before checking, adjusting, cleaning or repairing the gun or any part of the system.
- After adjusting or servicing the gun, if fluid does flow, the gun is not assembled properly or the trigger lock is damaged. Reassembled the gun or return it to your nearest distributor. Do not use the gun until the problem is corrected.
- When removing the gun from the hose, be sure to hold the inlet fitting securely to avoid loosening from the gun body.

REPLACE PRODUCT FILTER

ATTENTION: for further details, please refer to the drawing on page 22

- Insert the new filter (P3) as shown in the picture.
- Duly place the fitting in its seat (P2).

To replace the product filter, proceed as follows:

- Use the provided wrench (P1).

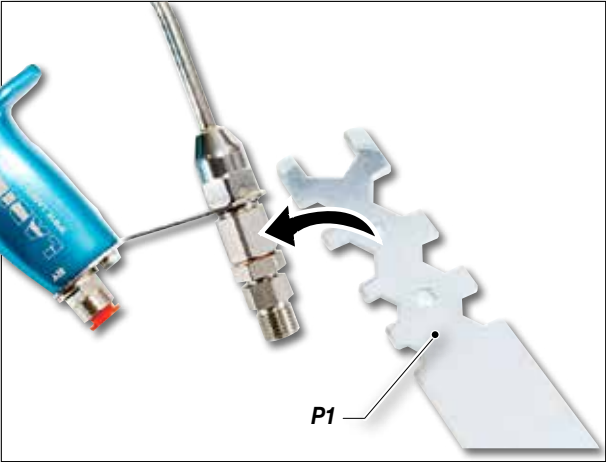

- Loose and remove the fitting (P2)

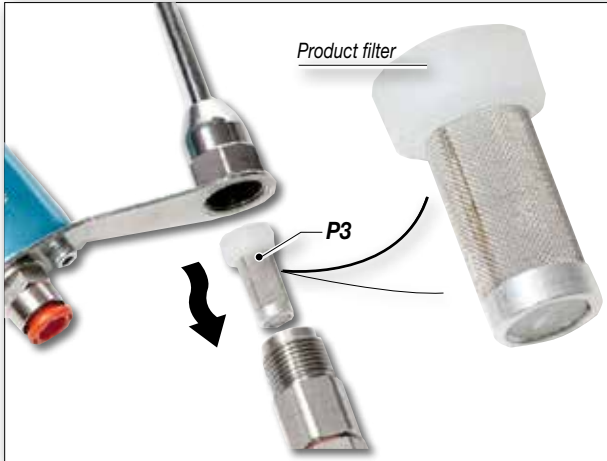
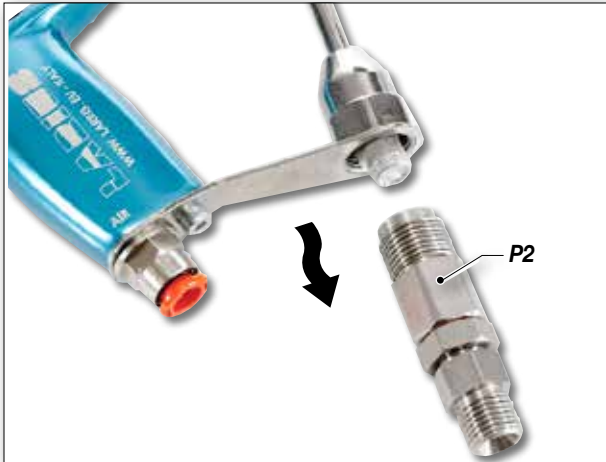

 On first use of the gun check for any leaks of product from the ring (P2).

- Remove the product filter (P3) and replace it with a new one.
NOTE: should the filter be blocked, use the pliers to remove it easily.



REPLACE PRODUCT GASKET

ATTENTION: for further details, please refer to the drawing on page 16

To replace the product gasket, proceed as follows:

- Unscrew the head (P4) .

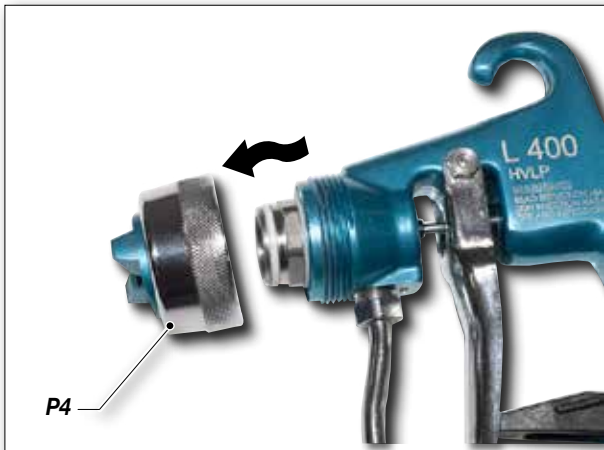

- Holding down the trigger (P5) with your hand, unscrew the coupling group (P6) with the provided wrench (P7).

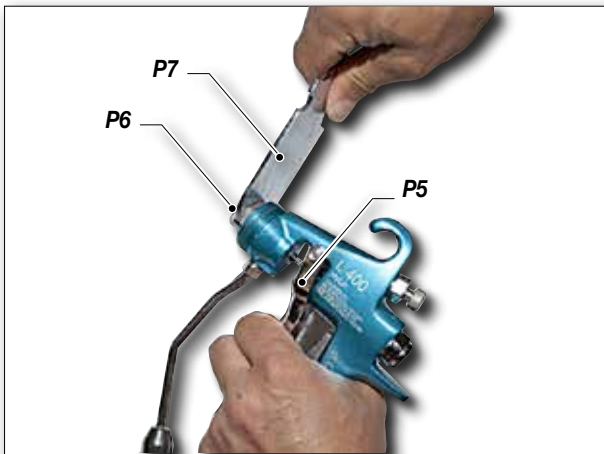

- Use the provided wrench (P11) to unscrew the nut (P9) and the pivot (P10) and disassemble the trigger (P8).

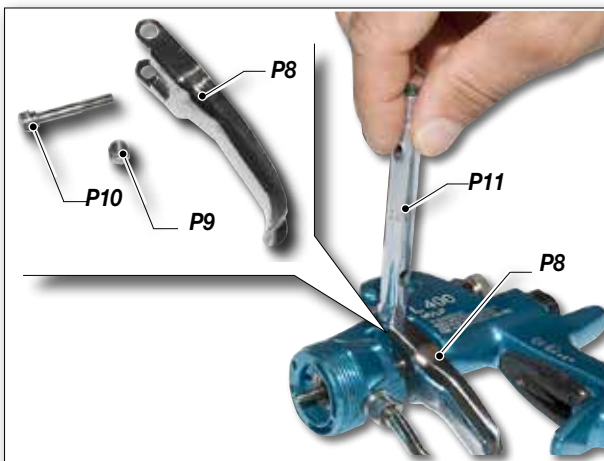

- Hold the nut (P12) with pointed pliers. (P13). Unscrew the needle (P14) and remove the bushing (P15).
- During this operation, check the needle (P14) and the needle tip (P16) whose surface shall not be damaged or worn. Replace it, if necessary.

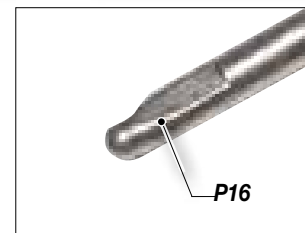
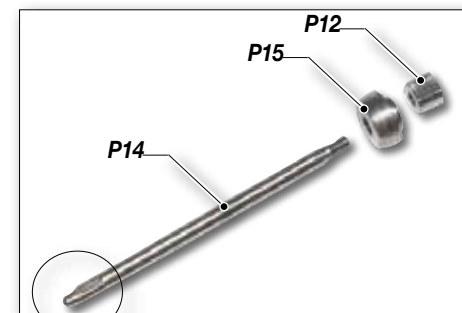
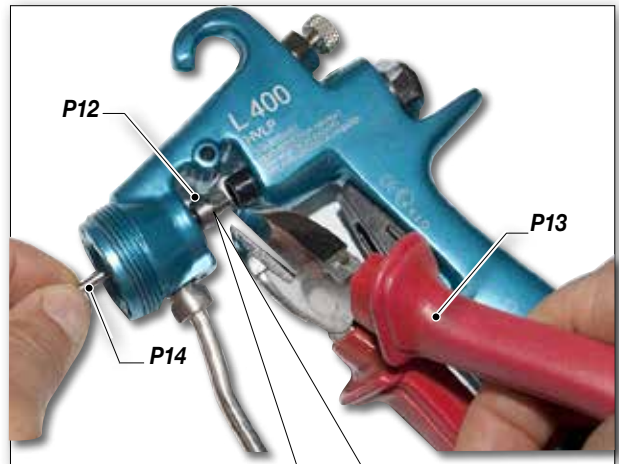

 Pay attention to the direction of the bushing (P15) in order to grant its correct positioning.



- Unscrew the gaskets group (P17) with the provided wrench (P18) and replace the OR gasket (P19).
- Remove the O-ring (P20) and the gasket (P21) inside the gaskets group.

- Position the product gaskets group (P22) inside the gun, making sure to lubricate the threads with grease.

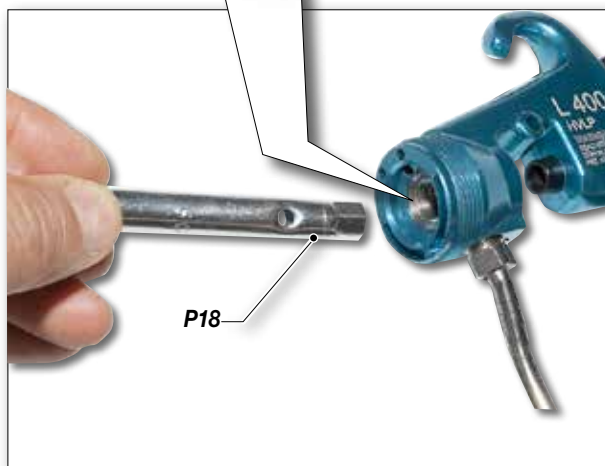
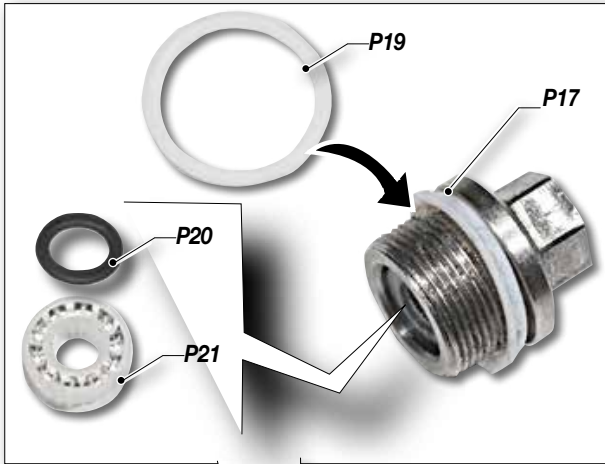

- Place the needle (P23) inside the gun, making sure to lubricate the surface with grease.

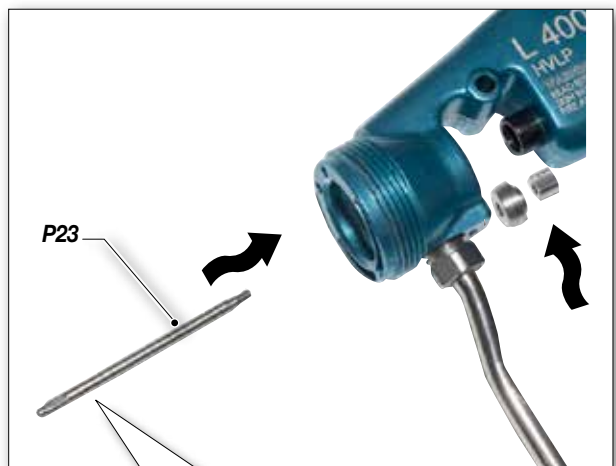

⚠ During assembling, pay attention to the direction of the gasket (P21) which should be placed with the sealing lip facing inward (see picture below).

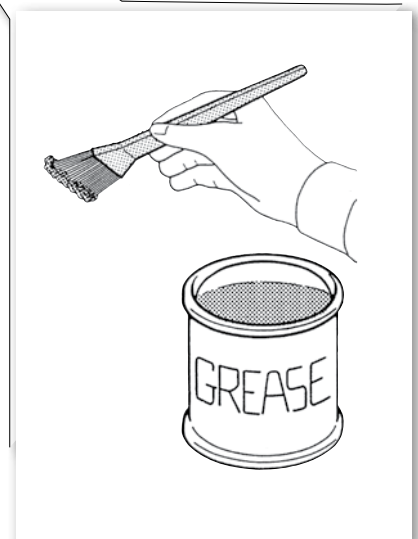



- Fasten the needle (P25) by using pointed pliers (P26).

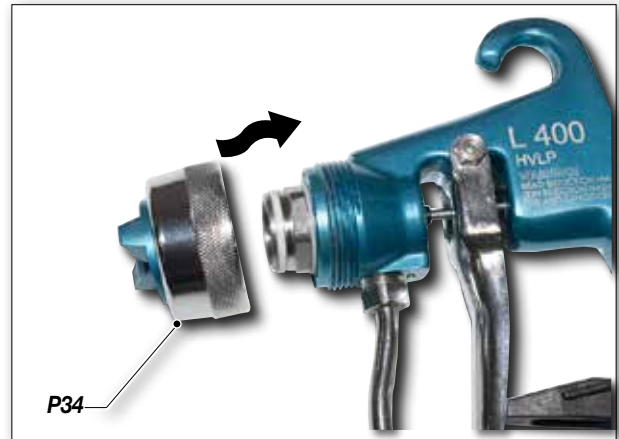

At this point the procedure for the gasket replacement is completed.

- Use the provided wrench (P30) to screw the nut (P28) and the pivot (P29) and assemble the trigger (P27).

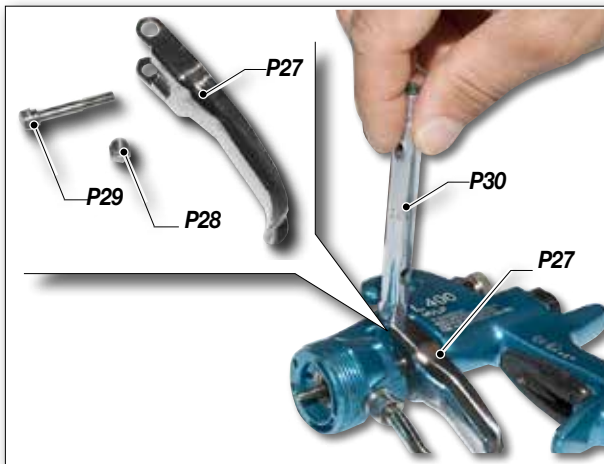

REPLACE THE COUPLING GROUP

ATTENTION: for further details, please refer to the drawing on page 22

To replace the coupling group, proceed as follows:

- Remove the ring nut (P35).

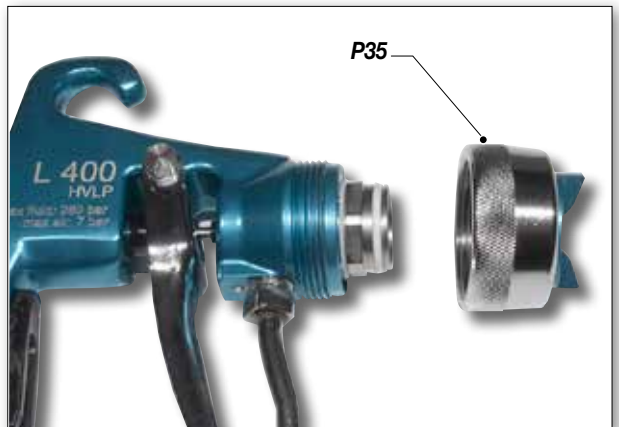

- Hold the trigger (P31) with your hand and unscrew the coupling (P32) with the provided wrench (P33).

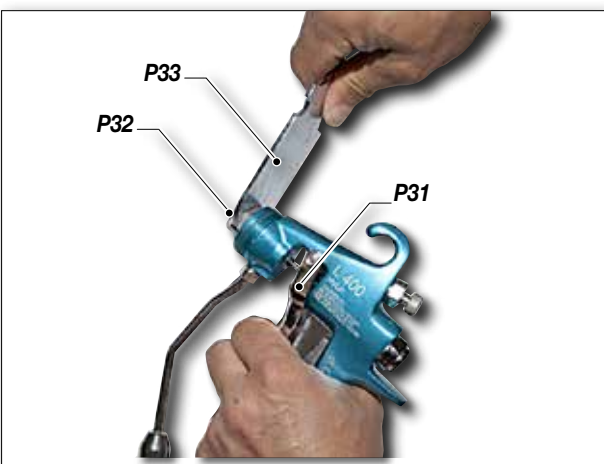

- Hold the trigger (P36) with your hand, unscrew the coupling group (P37) with the provided wrench (P38) and replace with a new spare part (P39).

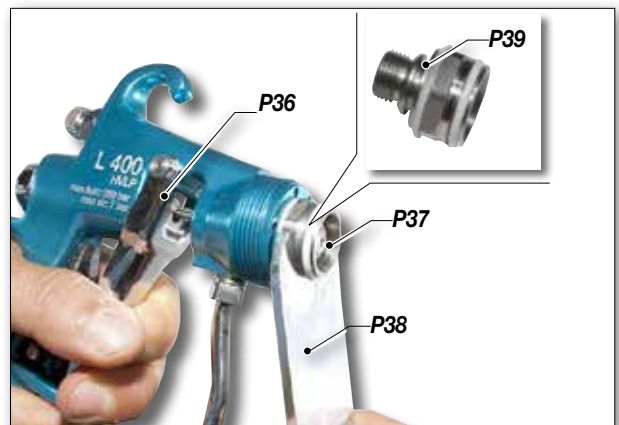

- Reassemble the head (P34) and the ring nut with the nozzle.



 During this operation, make sure that the needle is not damaged or worn (P40). If necessary, replace it as described in the previous paragraph "Replace product gasket".

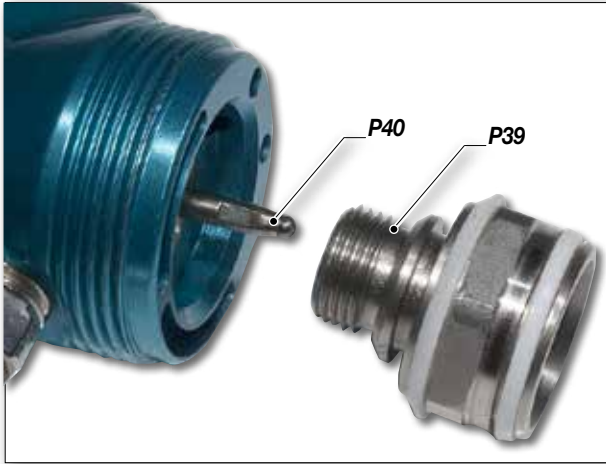

- Use the provided wrench (P48) to unscrew the nut (P46) and the pivot (P47) and disassemble the trigger (P45).

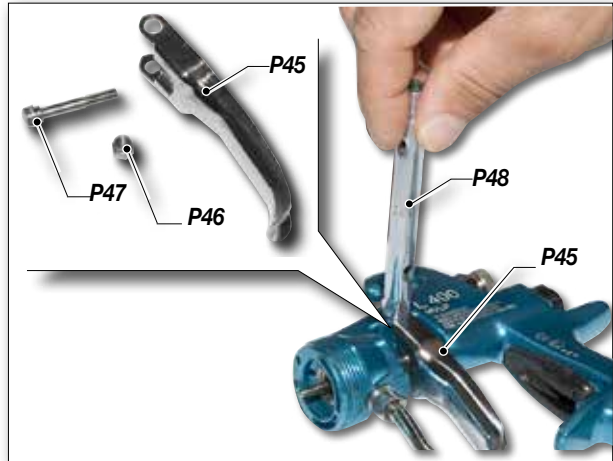

- Remove the air valve (P49) by using pointed pointed pliers (P50).

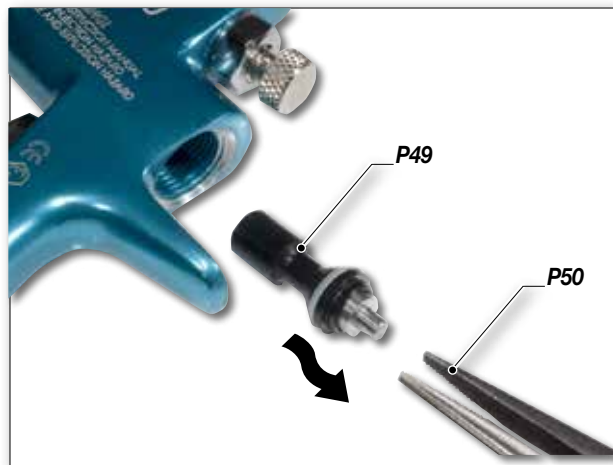

At this point the procedure for the coupling group replacement is completed.

Reassemble the gun following the previous procedure in reverse order.

REPLACE THE AIR VALVE GASKET

ATTENTION: for further details, please refer to the drawing on page 22

To replace the air valve gasket, proceed as follows:

- Use the provided wrench (P41) to remove the rear cap (P42) and the spring (P43) and (P44).

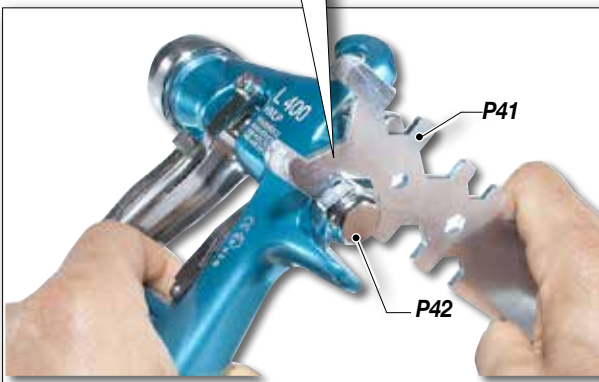
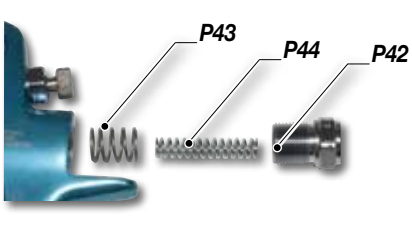

- Remove the ring nut (P51) and the coupling (P52).

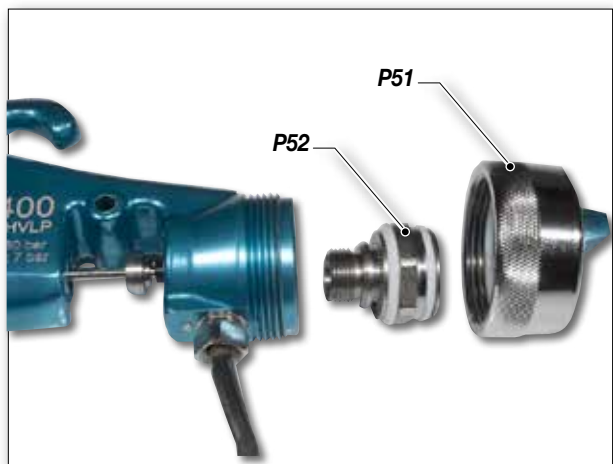



- Remove the gasket (P53) from the gun (P54) by using a pointed screwdriver (P55). Replace the worn gasket with a new spare one.

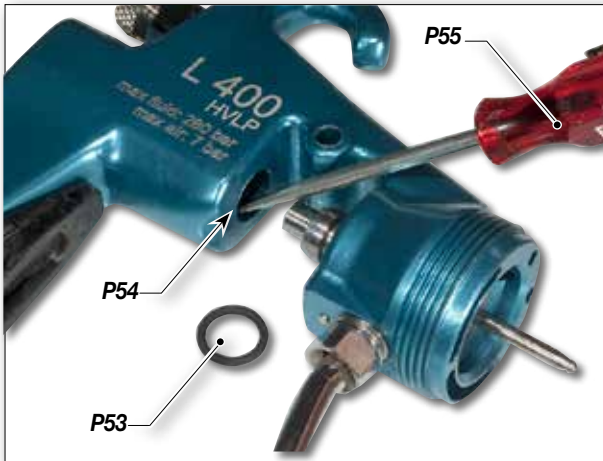

- Place the gaskets ring (P61) inside the air valve (P62).

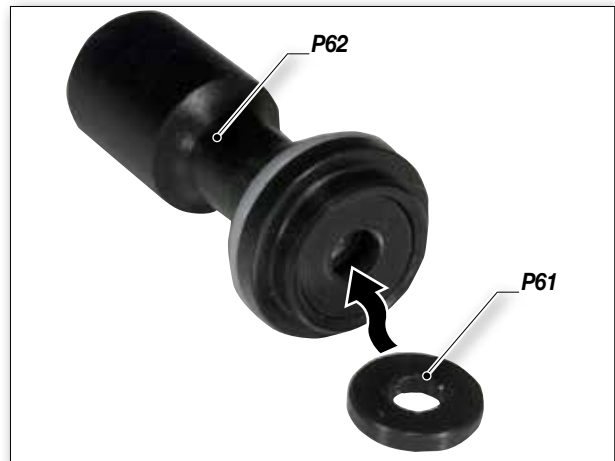

- Assemble the gaskets of the air valve (P56). Place the gasket (P57) in its seat (P58) as shown.



- Place the air control needle (P63) inside the air valve (P64) and assemble the whole group inside the gun body (P65).

 Before inserting the air valve, lubricate the valve surface with grease (P64) as shown in the previous picture.

 During assembling, pay attention to the direction of the gasket (P57) which should be placed as shown in the picture above.



- Insert the gasket (P59) inside the air valve (P60) making sure it is duly placed as shown in the picture.





- Slide the air valve (P66) until it comes out from the front side of the gun body by using the provided wrench (P67).

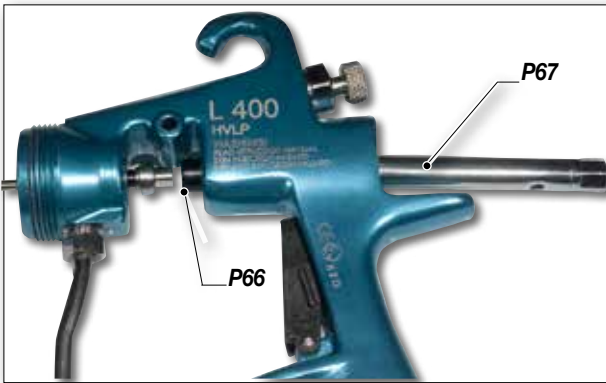

- Reassemble the springs (P68) and (P69) and the cap (P70).

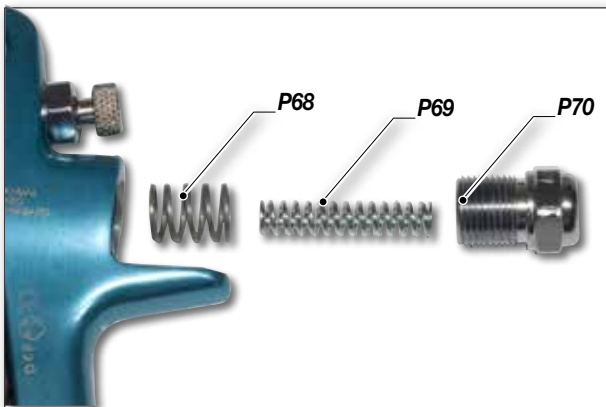

- Reassemble the cap (P71) by using the provided wrench (P72).

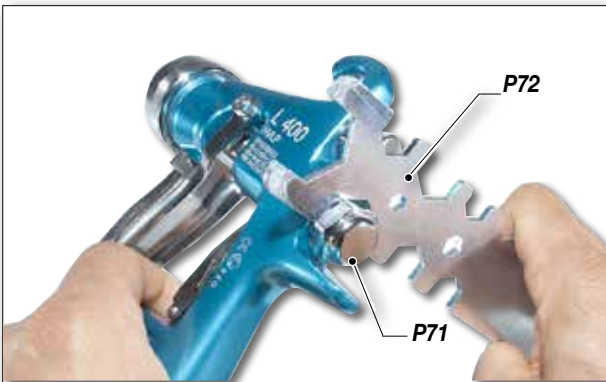

- Screw the nut (P74) and the pivot (P75) with the provided wrench (P76) to reassemble the trigger (P73).

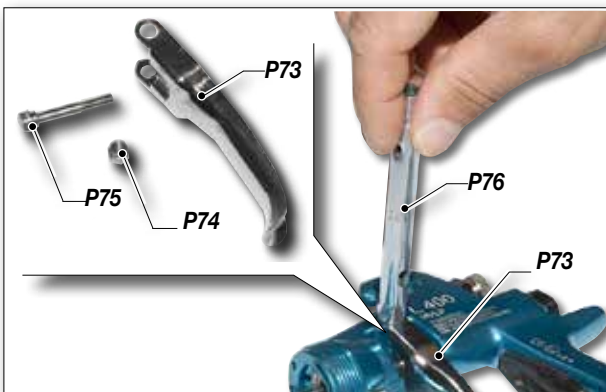

- Hold the trigger and reassemble the coupling (P78) and the ring nut (P77).

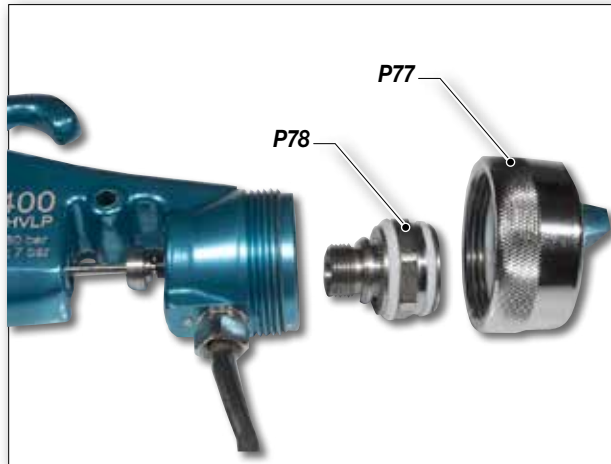

At this point the procedure for the air valve gasket replacement is completed.

REPLACE THE BUSHING GASKET FOR AIR ADJUSTMENT NEEDLE

ATTENTION: for further details, please refer to the drawing on page 22

To replace the air valve gasket, proceed as follows:

- Unscrew the hex nut of the air regulator (P79) with the provided wrench.



- Remove completely the air regulator from the gun body (P80).

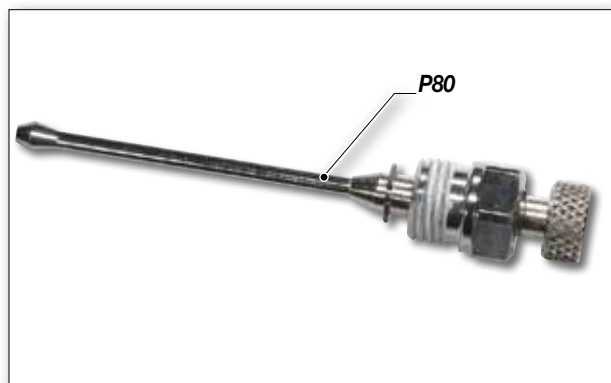



- Use pointed pliers (P81) to remove the elastic ring (P82). Then, completely loose the screw (P83) and remove it from the bushing (P84).

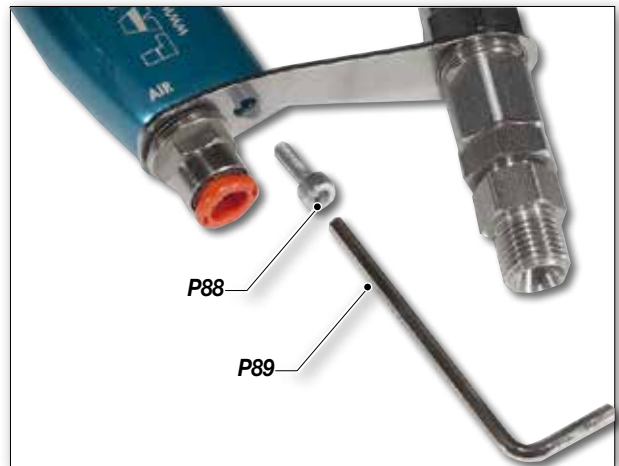
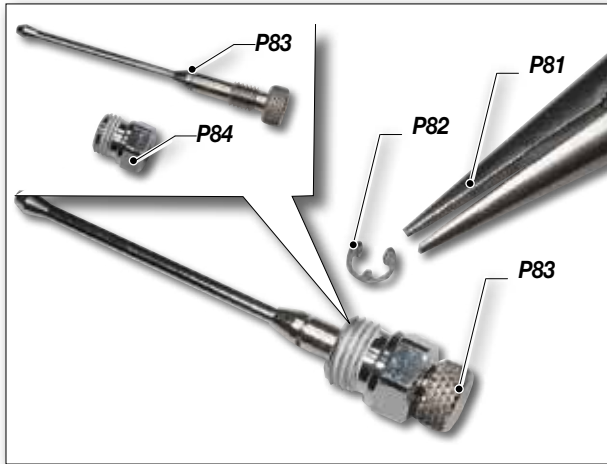

- Remove the revolving fitting (P90).

- The gasket (P86) is placed inside the bushing (P85). Use a suitable tool to remove the worn gasket and replace it with a new spare one (P87).

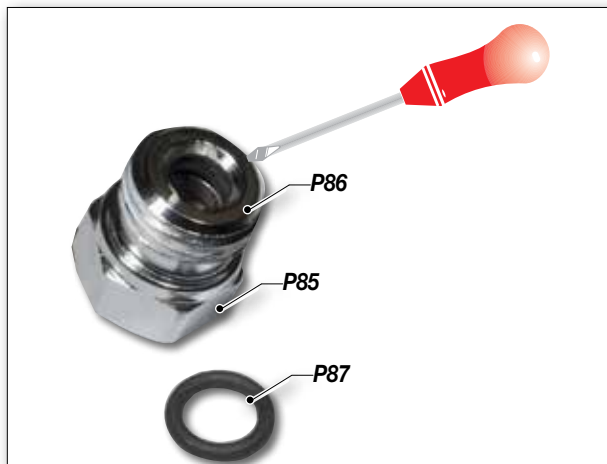

- Use a suitable wrench (P93) to loose the hex nut (P92) and then remove the product house (P91).

At this point the procedure for the bushing gasket replacement is completed. Reassemble the gun following the previous procedure in reverse order.

REPLACE THE PRODUCT HOUSE GASKET

ATTENTION: for further details, please refer to the drawing on page 22

To replace the product house gasket, proceed as follows:

- Remove the screw (P88) of the house supporting bracket by using the suitable wrench (P89).





- Use a suitable screwdriver (P94) to remove the worn gasket (P95). Replace it with a new spare one (P96).

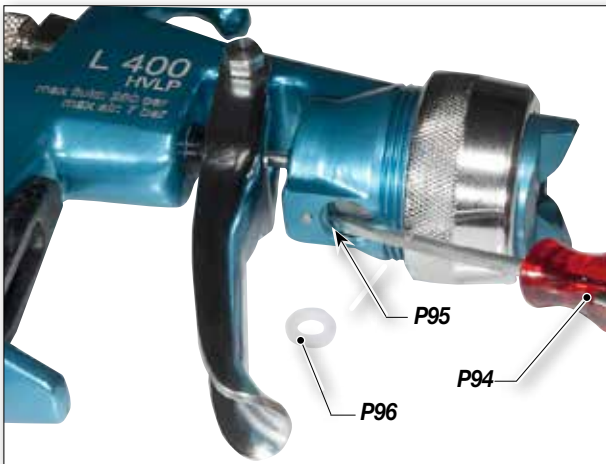

- Securely fasten with the provided hex wrench (P101).

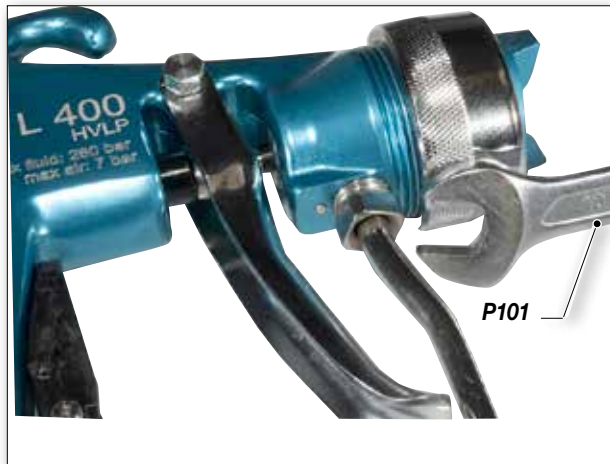

- Reassemble the product house (P97) by screwing the hex nut (P98) with your hand without overtightening.

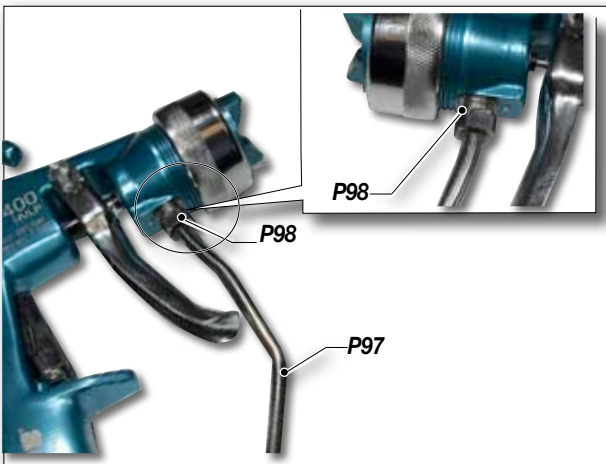

- Securely fasten the screw (P102) and the revolving fitting (P103).

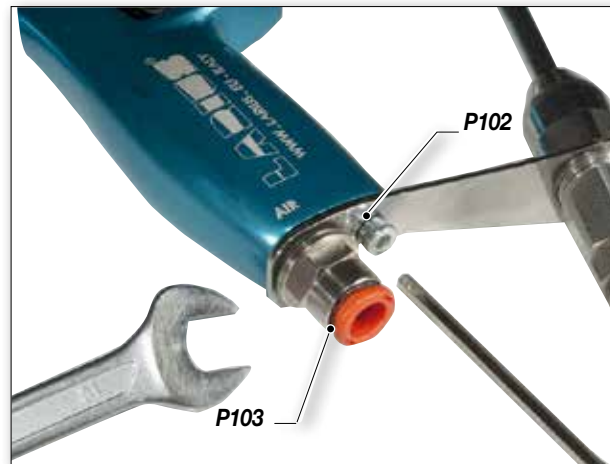

- Fasten with your hand the screw (P99) and the revolving fitting (P100) without overtightening.

At this point the procedure for the product house gasket replacement is completed.

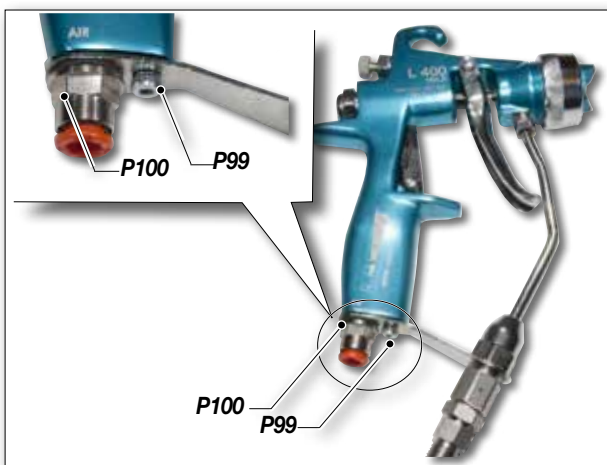



Q MIST-LESS MANUAL GUN L-400

WARNING: Always indicate code and quantity for each part required.

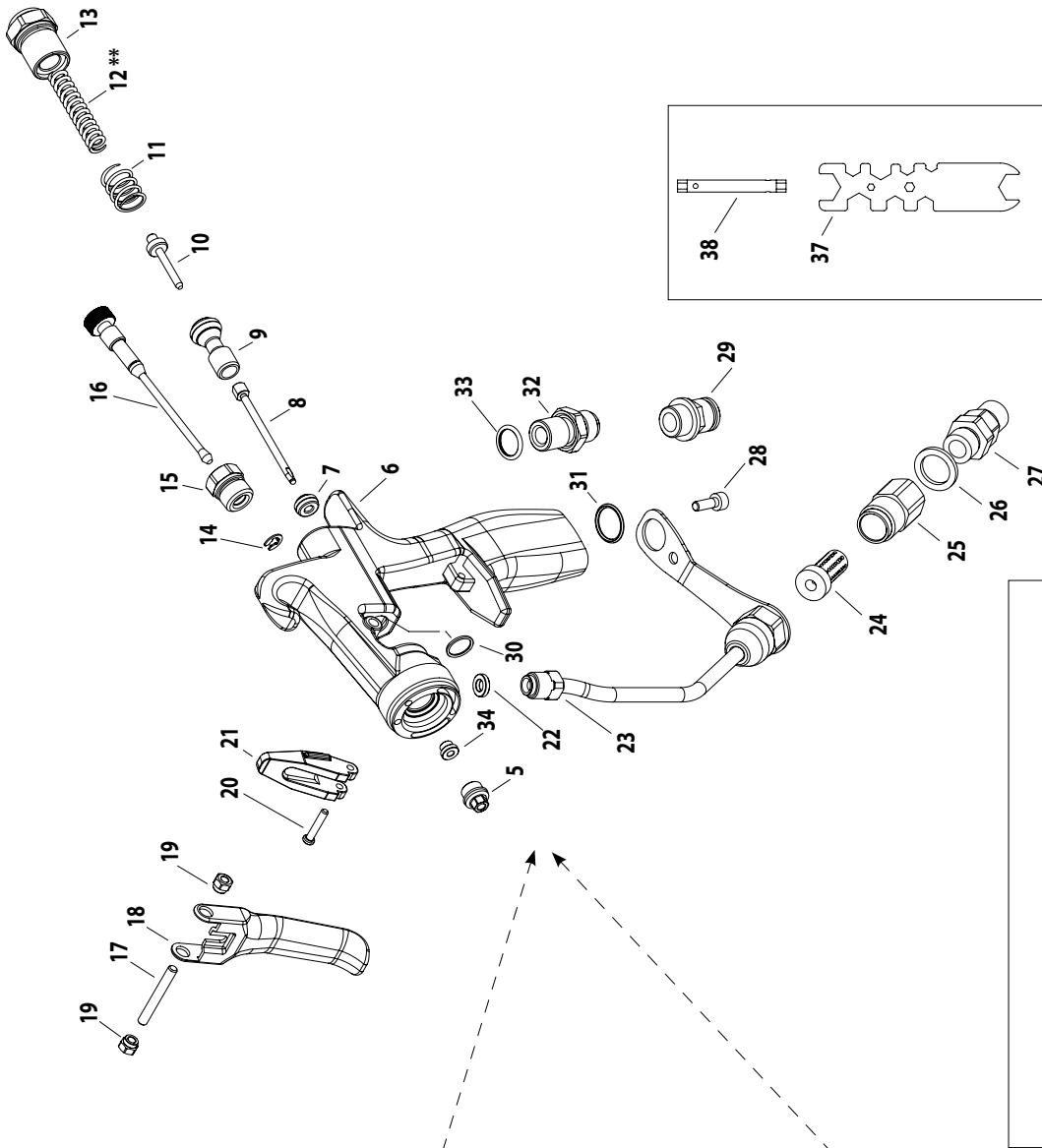

* to order only the nozzle seal use the part number 21854.
Mist-less nozzles codes are listed in chapter T.

** code 21882: spring 0-100 bar
code 21833: spring 0-250 bar
code 21834: spring 0-150 bar

Version with Super Fast Clean

Pos.	Cod.	Descrizione
1	21900	Base for Fast-Clean nozzle
2	SFC	a + b + c
3	21910	Super fast Clean coupling
b+c	18280	Gaskets

Standard version



Pos.	Code	Description	Pos.	Code	Description
1	21811	Ring nut	20	21845	Trigger low pin
2	21892	Air cap	21	21846	Trigger lock
3	*	Nozzle *	22	21836/1	Gasket
4	21920	Coupling group	23	21837	Material house
5	21895	Complete coupling	24	270	Filter 100 mesh
6	21896	Gun body	25	21870	Fitting filter holder
7	21828	Valve guide	26	7021	Gasket
8	21897	Needle	27	11155	Revolving fitting
9	21898	Air Valve	28	5338	Screw
10	21831	Needle	29	4006	Quick connection
11	11049	Spring	30	12572	O-ring
12	**	Spring	31	21863	O-ring
13	21835	Cap	32	21877	Fitting
14	12103	Ring UNI 7434-4	33	21865	O-ring
15	21899	Air adjusting fitting	34	21823	Needle guide
16	21826	Air adjustment	35	21812	Gasket
	21806	Air adjustment - mod. mistclean	36	21860	O-ring
17	21849	Trigger pivot	37	21858	Tool
18	21848	Trigger	38	21890	Tool
19	21871	Nut			

* to order only the nozzle seal use the part number 21854.
Mist-less nozzles codes are listed in chapter T.

** code 21832: spring 0-100 bar
code 21833: spring 0-250 bar
code 21834: spring 0-150 bar

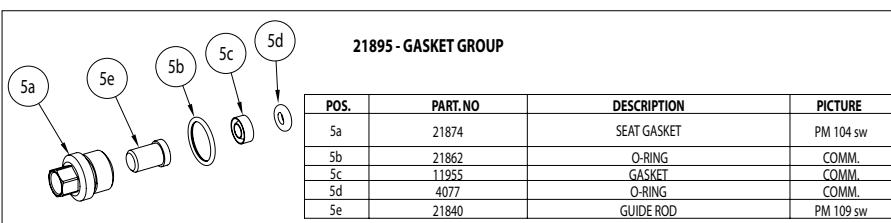
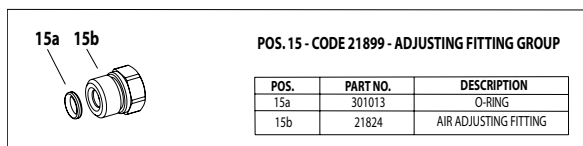
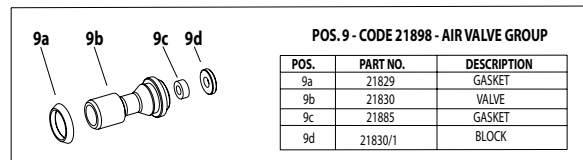
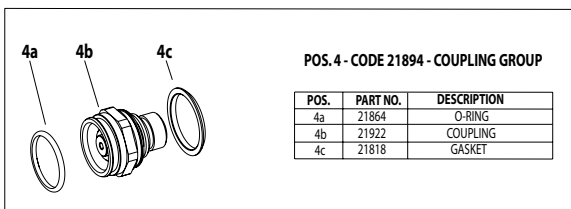
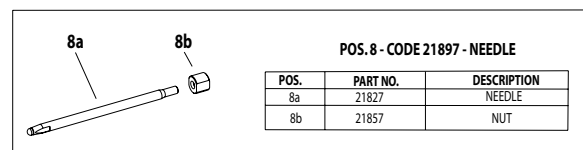
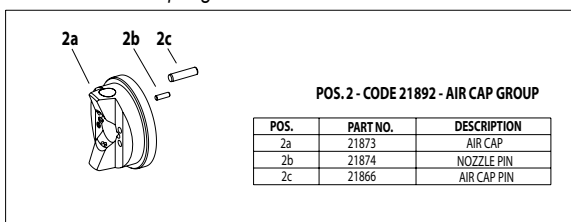



R UGELLI SUPER FAST-CLEAN (MIST-LESS)

Pos.	Cod.	Descrizione
1	21900	Base for Fast-Clean nozzle
2	SFC	a + b + c
3	21910	Super fast Clean coupling
b+c	18280	Gaskets

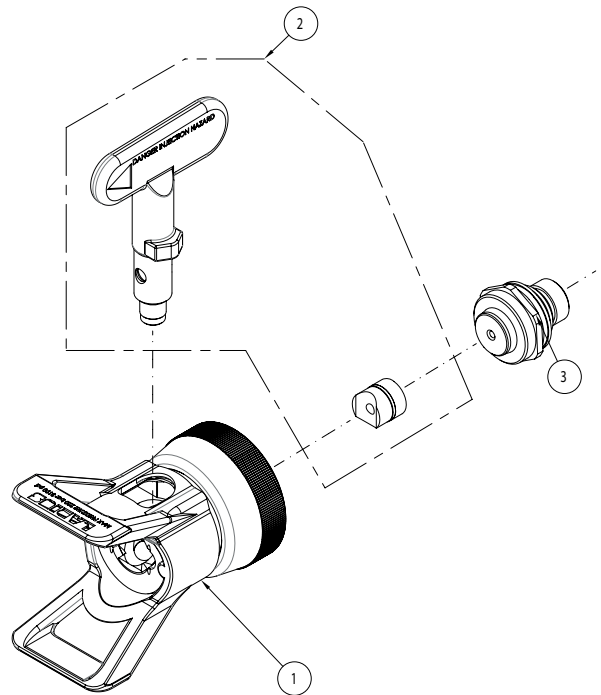

② a + b + c			
Size	Rate l/m 200 bar.	Size	Rate l/m 200 bar.
SFC 07-20	* 0,26	SFC 23-20	* 2,57
SFC 07-40	* 0,26	SFC 23-40	* 2,57
SFC 09-20	* 0,35	SFC 23-60	* 2,57
SFC 09-40	* 0,35	SFC 25-20	* 2,90
SFC 11-20	* 0,55	SFC 25-40	* 2,90
SFC 11-40	* 0,55	SFC 25-60	* 2,90
SFC 13-20	* 0,80	SFC 27-20	* 3,50
SFC 13-40	* 0,80	SFC 27-40	* 3,50
SFC 13-60	* 0,80	SFC 27-60	* 3,50
SFC 15-20	* 1,10	SFC 27-80	* 3,50
SFC 15-40	* 1,10	SFC 29-20	* 4,30
SFC 15-60	* 1,10	SFC 29-40	* 4,30
SFC 17-20	* 1,41	SFC 29-60	* 4,30
SFC 17-40	* 1,41	SFC 29-80	* 4,30
SFC 17-60	* 1,41	SFC 31-40	* 4,83
SFC 19-20	* 1,77	SFC 31-60	* 4,83
SFC 19-40	* 1,77	SFC 31-80	* 4,83
SFC 19-60	* 1,77	SFC 33-40	* 5,50
SFC 21-20	* 2,15	SFC 33-60	* 5,50
SFC 21-40	* 2,15	SFC 33-80	* 5,50
SFC 21-60	* 2,15	SFC 35-40	* 6,00

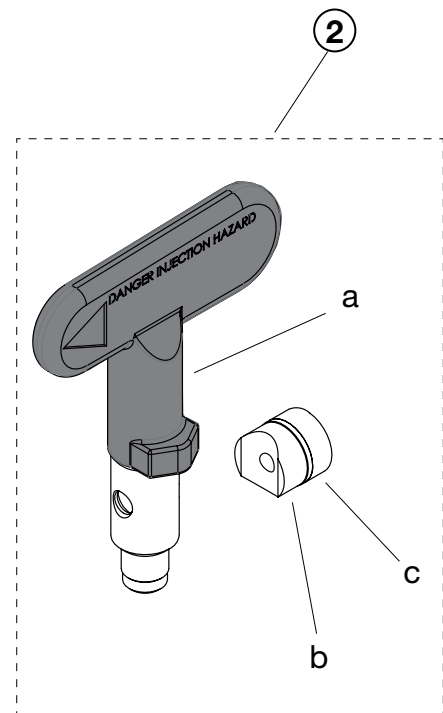



S MIST-LESS NOZZLES

Nozzle code	Size
21951	7-20
21952	7-40
21953	7-65
21954	9-20
21955	9-40
21956	9-65
21957	9-80
21958	11-25
21959	11-40
21960	11-60

Nozzle code	Size
21961	13-20
21962	13-40
21963	13-60
21964	13-80
21965	15-25
21966	15-40
21967	15-60
21968	15-80
21969	17-25
21970	17-40

Nozzle code	Size
21971	17-65
21972	21-25
21973	21-40
21974	21-60
21975	25-25
21976	25-40
21977	25-65
21978	31-40
21979	31-65

T NOZZLES TOP SPRAYING CLEAN

② a + b + c		
Size	Size	Size
TSC 7-20	TSC 15-40	TSC 21-60
TSC 7-40	TSC 15-60	TSC 23-20
TSC 9-20	TSC 17-20	TSC 23-40
TSC 9-40	TSC 17-40	TSC 23-60
TSC 11-20	TSC 17-60	TSC 27-20
TSC 11-40	TSC 19-20	TSC 27-40
TSC 13-20	TSC 19-40	TSC 27-60
TSC 13-40	TSC 19-60	TSC 31-40
TSC 13-60	TSC 21-20	
TSC 15-20	TSC 21-40	

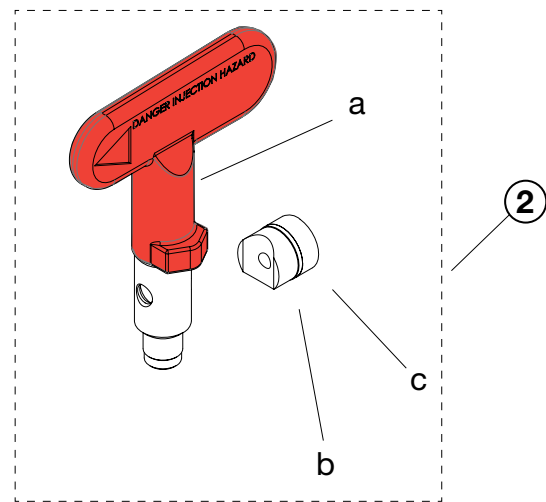

U BASE MIST-CLEAN 2

CODE	Description
21900	Base Mist-clean

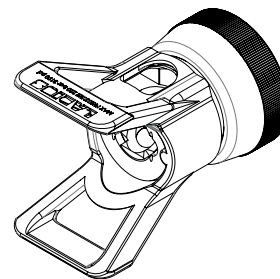

V KIT AND SPARE PARTS

Cod.	Description
21910	Complete SFC nozzle coupling
21915	Complete SFC nozzle coupling + Mist-Clean 2 base
21920	Complete Mist-less nozzle coupling
21930	Complete SFC nozzle coupling + needle
21935	Complete Mist-less nozzle coupling + needle
21940	Gaskets kit for Mist-less manual gun L400

 The Mist-less gun is provided with a closing spring which allows it to operate with a maximum working pressure of 110 bar. To operate with max 280 bar pressure it is necessary to fit the "reinforced" spring provided in the case.



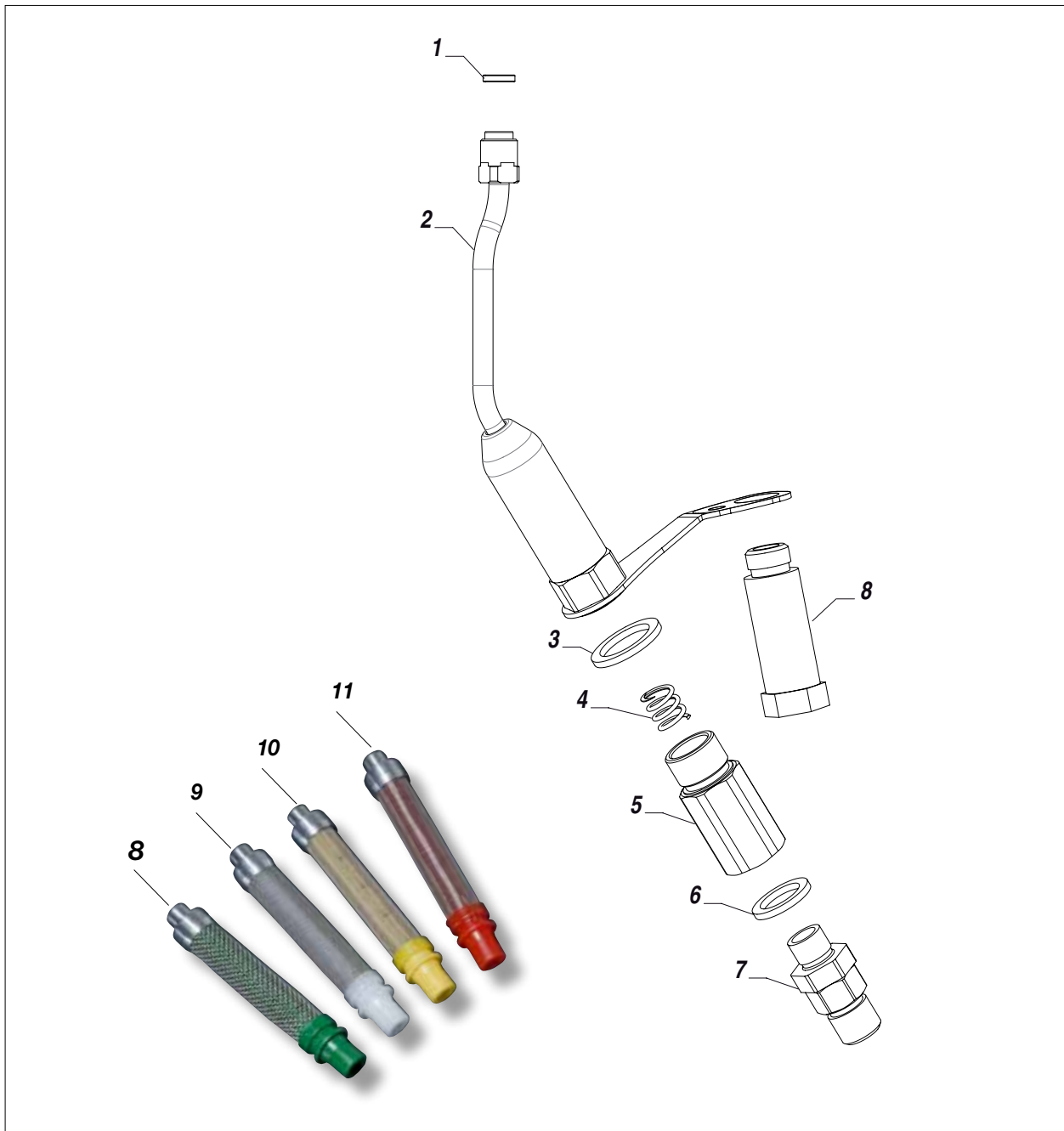

W LONG FILTER MATERIAL HOUSE COMPLETE KIT REF. 21980

WARNING: Always indicate code and quantity for each part required.

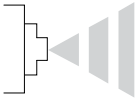
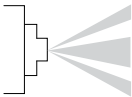

Pos.	Code	Description	Pos.	Code	Description
1	21836/1	Gasket	7	11155	Revolving fitting
2	21867	Long filter material house	8	21911	Long filter 30 mesh - green
3	33010	Copper gasket	9	21912	Long filter 60 mesh - white
4	11017	Spring	10	21913	Long filter 100 mesh - yellow
5	21868	Fitting	11	21914	Long filter 200 mesh - red
6	7021	Copper gasket			

**X TROUBLESHOOTING**

Problem	Cause	Solutions
<ul style="list-style-type: none"> Pulling the trigger, the pressure drops considerably 	<ul style="list-style-type: none"> The nozzle is too large or worn; The product is too dense; The mesh of the filter in the gun is too fine; 	<ul style="list-style-type: none"> Replace with a smaller one; If possible, dilute the product; Replace with a filter with larger mesh;
<ul style="list-style-type: none"> Material flows from the cap 	<ul style="list-style-type: none"> Material leakage from the sealing Oring; 	<ul style="list-style-type: none"> Replace the O-ring;
<ul style="list-style-type: none"> Fluid leakage from the gun 	<ul style="list-style-type: none"> Gaskets worn; Product viscosity too low; Fluid rod damaged or worn; 	<ul style="list-style-type: none"> Replace the gaskets; Change to a more suitable product; Check and replace if necessary;
<ul style="list-style-type: none"> Fluid in air passages 	<ul style="list-style-type: none"> Leaks from the gaskets; 	<ul style="list-style-type: none"> Replace the gaskets;
<ul style="list-style-type: none"> Fluid flow stops or it comes out slowly 	<ul style="list-style-type: none"> Nozzle dirty or clogged; 	<ul style="list-style-type: none"> Clean or replace it;
<ul style="list-style-type: none"> Material leaks from the gasket pressing screw 	<ul style="list-style-type: none"> Gasket loosened or worn; 	<ul style="list-style-type: none"> Tighten the gasket pressing screw or change the gasket;
<ul style="list-style-type: none"> Atomization imperfect 	<ul style="list-style-type: none"> Nozzle worn; 	<ul style="list-style-type: none"> Replace it;
<ul style="list-style-type: none"> Spraying jet irregular 	<ul style="list-style-type: none"> Insufficient fluid feed; Air in the paint feed line; Nozzle worn; 	<ul style="list-style-type: none"> Adjust the fluid outflow or fill the fluid feed can; Check and bleed the paint line air; Replace it;
<ul style="list-style-type: none"> Spraying jet streaky 	<ul style="list-style-type: none"> Nozzle partially clogged; 	<ul style="list-style-type: none"> Clean or replace it;
<ul style="list-style-type: none"> Uneven paint spreading 	<ul style="list-style-type: none"> Nozzle worn or partially clogged; 	<ul style="list-style-type: none"> Clean or replace it;
<ul style="list-style-type: none"> Pulling the trigger, the fluid does not flow out 	<ul style="list-style-type: none"> Nozzle clogged; Filter clogged or worn. 	<ul style="list-style-type: none"> Clean or replace it; Clean or replace it.



Incorrect spreading of the product is caused by incorrect adjustment between the air and the fluid.



Y VERSIONS

Code 21800



Mist-less manual gun L400
for Mist-less nozzle

Code 21807



Mist-less manual gun L400
complete with Super Fast Clean or
Top Spraying Clean nozzle

Code 21802



Mist-less manual gun L400
for Mist-less nozzle with long filter

Code 21803

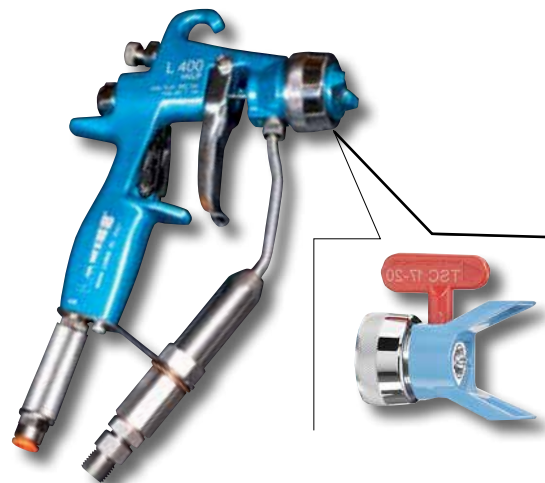

Mist-less manual gun L400
complete with Super Fast Clean or
Top Spraying Clean nozzle with long filter



LARIUS®

Transfer - Extrusion - Injection pumps - Paint spraying equipment

www.larius.eu



DIRECT LINE

CUSTOMERS TECHNICAL SERVICE

Tel. (39) 0341.621256 - Fax (39) 0341.621234

COSTRUTTORE:

LARIUS®

Transfer - Extrusion - Injection pumps - Paint spraying equipment

Paint spraying equipment

23801 **CALOLZIOCORTE** - LECCO - ITALY - Via Antonio Stoppani, 21

TEL. (+39) 0341/62.11.52 - Fax (+39) 0341/62.12.43

E-mail: larius@larius.com - Internet <http://www.larius.eu>